

CLASS OF 2019

GRADUATE REPORT

Hope graduates are educated to think about important issues with clarity, wisdom and a deep understanding of the Christian faith. They make an impact at organizations, companies and graduate schools around the country and abroad. This summary of the annual Graduate Report gives a six-month snapshot of the Class of 2019.

CLASS SNAPSHOT

96%

in graduate school or no longer seeking employment within six months



76%
EMPLOYED



15%
GRADUATE SCHOOL



4%
NOT EMPLOYED, SEEKING



3%
VOLUNTARY SERVICE



2%
NOT EMPLOYED, NOT SEEKING

EMPLOYMENT AND GRADUATE SCHOOL BY REGION

% EMPLOYED | % GRAD SCHOOL

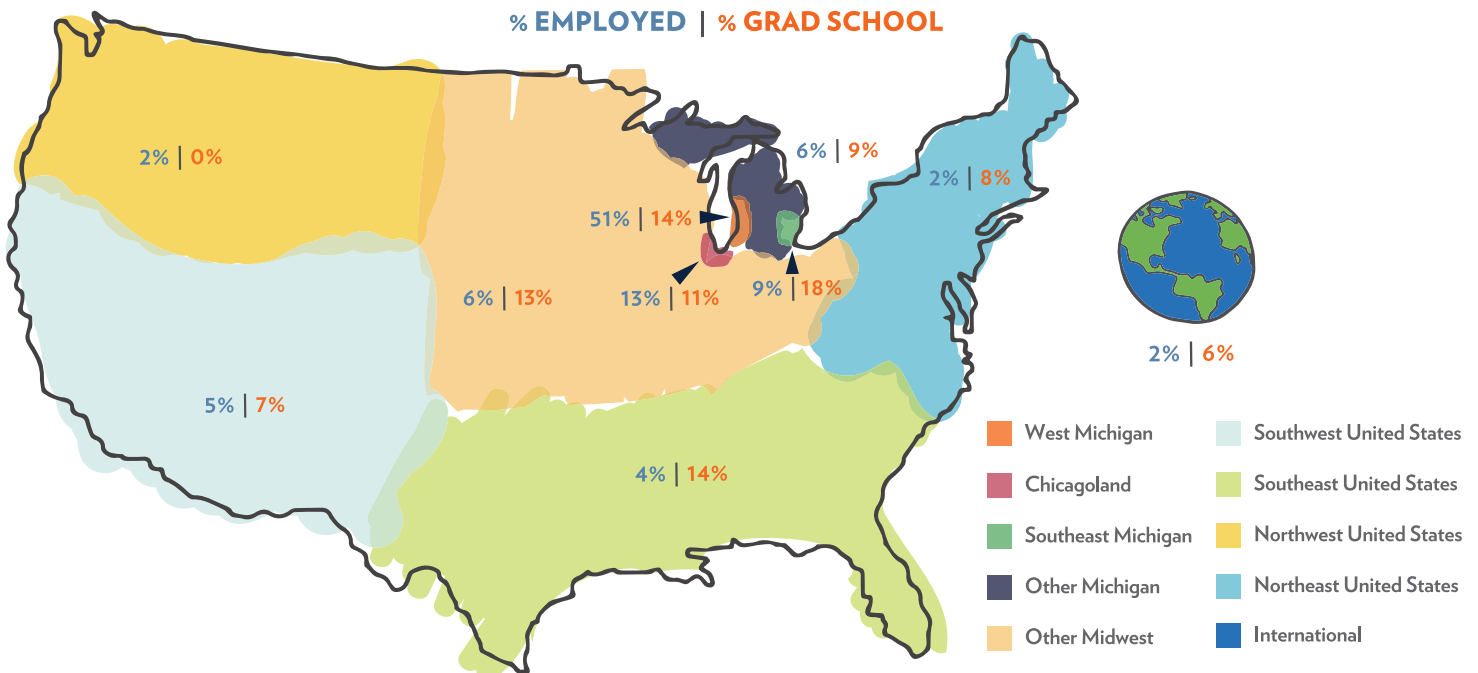

This study is administered annually by the Frost Center for Data and Research, Alumni and Family Engagement, the Boerigter Center for Calling and Career, and Admissions. Alumni are contacted 5-6 months after graduation by email, mail and telephone. The data presented on this page has a knowledge rate of 83%, including 399 survey responses, conducted by the Frost Center for Data and Research, and information on 111 individuals from online research, conducted by Alumni and Family Engagement. The remainder of this report is based on the 399 survey responses. For additional requests or data from previous years, please contact the Frost Center for Data and Research at 616.395.7556 or frostcenter@hope.edu.

CLASS OVERVIEW

TOP MAJORS (by number of graduates)

- | | |
|---------------------|-------------------|
| Business | Communication |
| Psychology | Engineering |
| Nursing | Social Work |
| Education Certified | Political Science |
| Biology | Exercise Science |

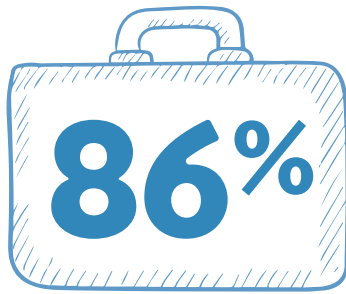

of those employed full-time are employed in their field of study

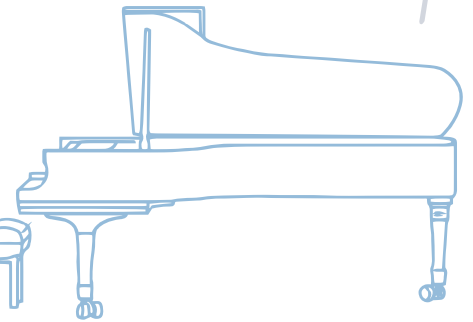

$$\begin{array}{r} 10 \overline{) 2 \sqrt{46} \sqrt{64}} \\ \underline{23} \cdot 2 = 23 \cdot 3 \\ 23 \sqrt{6} \end{array}$$

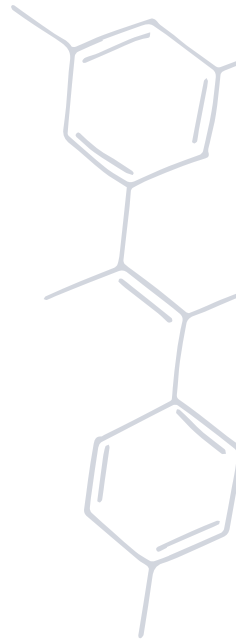
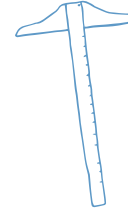

93%



participated in experiential learning opportunities, such as internships, off-campus study and collaborative student-faculty research

90%

connected with a faculty or staff member about their vocational future



84%

are likely or very likely to refer someone else to Hope College for their education

88%

were active in extracurricular activities and organizations



EMPLOYMENT

(6 MONTHS AFTER GRADUATION)

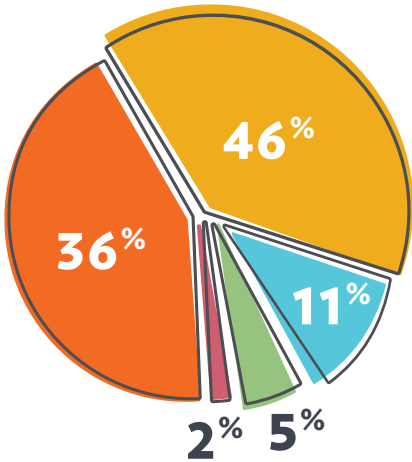

82%

are satisfied or very satisfied with their employment



Very Satisfied Satisfied Neither Dissatisfied Very Dissatisfied

RECENT EMPLOYERS

Beaumont Hospital
Bethany Christian Services
CareerBuilder
Epic Systems
GE Aviation
Gordon Food Service
Helen DeVos Children's Hospital

Herman Miller
Holland Hospital
Hope Network
JR Automation
Mayo Clinic
National Football League
Pine Rest

Royal Cyber
Saugatuck Center for the Arts
Spectrum Health
Steelcase
TEKsystems
U.S. Anti-Doping Agency

GRADUATE SCHOOL



98%

of those who applied were accepted to their first or second choice graduate school

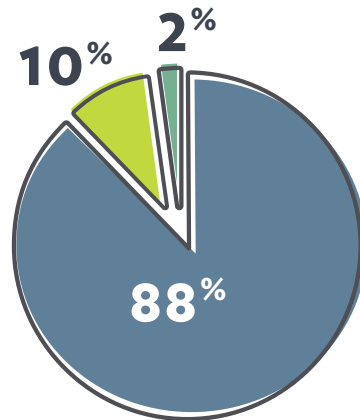

First Choice
Second Choice
Other

RECENT GRADUATE SCHOOLS

Duke University
Grand Valley State University
Jerusalem University College
Johns Hopkins University
Loyola University
Michigan State University
Northwestern University

Tufts University
University College London
University of Chicago
University of Edinburgh
University of Illinois
University of Michigan
University of North Carolina

University of Pennsylvania
University of Wisconsin
Western Michigan University
Western Theological Seminary
Yale Divinity School

EXPERIENTIAL LEARNING

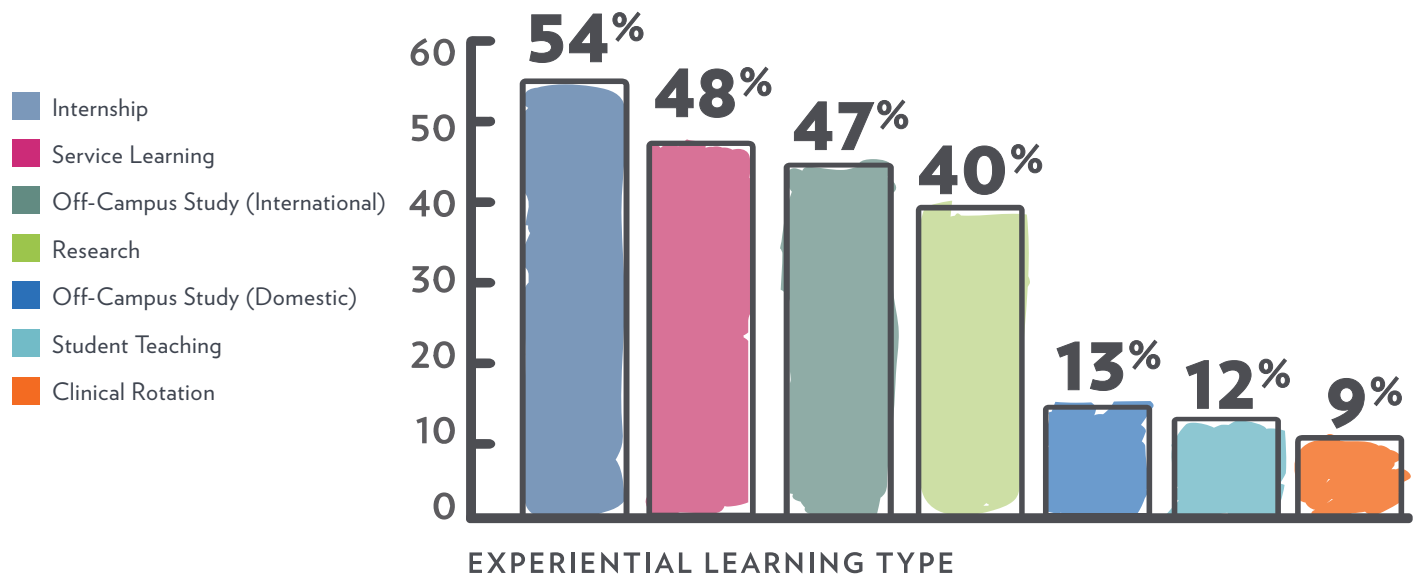

95%

of the Class of 2019 shared that their professors cared about them as a person.



CAMPUS RESOURCES



BOERIGTER CENTER FOR CALLING AND CAREER

The principal goal of the Boerigter Center is to teach students how to engage in lifelong practices of career development.

- Discern: Identify strengths and interests, absorb the liberal arts and deepen sense of vocation and core character.
- Prepare: Explore paths, expand intellect, develop skills and extend perspectives through experiences on campus and around the world.
- Pursue: Strategize for life after college, activate networks and achieve next steps.

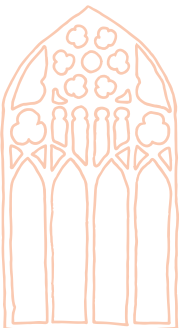

ALUMNI ASSOCIATION



In partnership with the Boerigter Center for Calling and Career, the Alumni Association hosts an online career center where you can work on your résumé, join and use The Hope College Connection, volunteer, find job postings, connect with social media and sign up for events. Connect at hope.edu/alumni.

HANDSHAKE

Students and alumni can browse thousands of job and internship postings on Hope's online job board, Handshake. Start searching at hope.edu/handshake.